

Keynote Address

HOW AND WHY SACRED SPACES ALTER HUMAN CONSCIOUSNESS¹

by Freddy Silva

ABSTRACT

Since 8000 BC people have constructed temples around the world based on similar foundations: water, magnetism, strategic use of stone, and sacred geometry. The purpose was to generate an environment that not only stimulated the human energy field to achieve altered states of awareness, but also to induce healing—spiritually and physically. Many of these places on Earth are still used for such purposes. But what is significant is that the very same principles are found in genuine crop circles. And not only are people reporting altered states when they come into contact with these enigmatic symbols, they are also experiencing physical healing. And whatever resonant code exists in the crop circles can now be transferred onto cards and applied in remote therapy.

KEYWORDS: Temples, sacred sites, cathedrals, crop circles, resonance therapy, homeopathy, remote healing, water, cymatics, altered states

If you are an inquiring person like me who likes to travel the world and look at the sacred sites, have you ever wondered what these places really are for? More importantly, what these places do for us and also to us, physically and logically, and also physiologically. Why is it that whenever you travel around the world you find that there's a very subtle superimposition of a new religion over a very old patent tradition. By this I mean that when you go to places like Britain where we have one of largest repositories of ancient sacred sites anywhere in the world, at least man made ones, you find on occasion that there are these wonderful circular temples, which have been superimposed by these physical churches.

This is very curious because the word church in itself has a wonderful origin; it begins to give you a glimpse of what these places really were for. Because if you take the origin of the word church all the way back to its Greek roots it comes from a Greek word, kyrkos. It means both circle and the House of the Lord. Back in those days the Lord wasn't a physical sort of creation as it eventually became for the Catholic tradition. The Lord was a creative invisible force, something that manifested the universe in its many other forms. It does begin to make you wonder, why these circular temples were the houses of the Lord? What exactly were they creating? What was happening inside of these places?

Thousands of years ago there was a wonderful tradition of working with subtle forces on the land. Our ancestors left us this wonderful legacy all around the world.

Even in this part of the world, in New Mexico, where we actually still have a lot of Native American sacred sites. Even here, in Colorado, we have sacred sites. What our predecessors were basically working with was harnessing very subtle forces to communicate with the spirit world, or more permanently, to work with a creative force which they can actually harness to make their lives much more tangible and meaningful. However, round about 2400 BC something went slightly squiffy as we say in England. The sites became corrupted. Up to that point people were working with the female force of life. Even the guys were working with a female force of life. It was about creating. It was about working with a flowing side of nature. Around 2400 BC a change definitely took place; the sites began to be usurped by an elite group of people who recognized the energy is neutral. You can use it for great things. You can also use it to control people.

These sites began to get shut down, one after the other. If you look at places like West Kennet Long Barrow, you find an enormous 100 ton rock was placed right at the entrance, which is to signify whoever was in charge of these places knew that these temples would be corrupted and therefore they shut something off. The same thing happened with the great pyramids. The closing is done very deliberately because of the serious abuse going on in the land. By 640 AD the abuse of sacred space became paramount throughout the western world. By this point we have had the rise and decline of the Roman Empire, one of the greatest colonizing empires of the moment.

What happened was that these people who ran the Roman Empire also understood how to work with energy for the control of many, many people. By 640 AD we have a very interesting situation there because now we have the fall of the Roman Empire and with it we have a vacuum of power. Now if you look back at this age, I'll paint a very quick picture. In 640 AD we have a very unusual situation where the Christians are worshipping side by side with the Muslims who are worshipping side by side with the pagans. Very interesting, how far we've strayed away from that principle.

In my culture where I was born, I'm actually Portuguese by birth, you can tell. I collect nationalities for a living. I'm also a resident alien of America. I go to UFO conferences and I say I'm not this big and I'm not this green. Here's my card: resident alien. In my culture it's very interesting to see how the Muslims, Christians and the pagans actually honored each other. Because they recognized that they all worshiped the same thing. They just called God by different names. You come to my church and next week I can come over to your church or my mosque, not a big deal and the pagans were doing exactly the same thing. As the Roman Empire began to fall apart you have all of these people who are lacking a bit of control. The Roman Emperor sits around the big table and says, well how are we going to control these people around Europe? We have no centralized means to govern these myriads of people. Some bright spark says, "I know we invent something called the Roman Catholic Church."

Totally different from Christianity by the way. So we are talking about a completely different system of religion here. The Roman Catholic Church began to persecute the pagans and the Christians; at this point in time we began to see these edicts being sent around Europe, telling anybody who owns a church or a sacred space to do this: "Let no Christian place light at the temples or stone enclosures. Let no one presume to make lustrations or to enchant herbs or flocks to pass through a hollow of a tree or aperture of the earth. For by so doing he seems to consecrate them to the Devil." Interesting the work of the Devil at the time was any kind of knowledge that is outside the strict confines of orthodox Roman Catholic beliefs. Yet despite these orders it seems that the pagans didn't concede. Pagan, by the way, means someone who lives in the country.

I live in Portland, Maine, so we have very long winters. We have time to read books for about four months of the year. The best thing I can ever suggest is a book on etymology. Look up the meanings of words and their origins. It's amazing how words are so easily corrupted and pagan is one of my favorite ones. Look at the meaning of the word occult, that which is hidden from the eye, nothing to do with upside down pentagrams and devil worshipping.

Anyway, the pagans didn't seem to share the Roman Catholic Church's view that any use of sacred space in any way connected them with the forces of hell. Three-hundred years after these orders were sent out across Europe, they were still worshipping at

standing stones, sacred sites, holy trees, sacred wells and so forth. Something worked, something very miraculous worked at these sacred sites. By the eleventh century poor old pope Gregory in Rome is tearing his hair out because people are still going out to do strange things at sacred sites. He decides to make the worship of sacred sites absolutely illegal.

The penalties that came with worship at sacred sites were very severe. For example, if you were a mother who wanted to facilitate childbirth at a standing stone, which is still the practice today in many parts of northern Europe by the way, if you were caught, you were made to fast for three years. There was still enormous resistance to all of this because something worked.

So the church decided to take a completely different change of strategy. They began to assimilate the pagan sites. They were very subtle about it. This is where I came in, because I'm walking around the land looking at this stuff and I'm thinking, back then there weren't many people around. I figured why not just take these sites down, build a church somewhere else and be done with it. But no, the more I went around Europe the more I realized there was a very obvious superimposition of all sacred sites. So what was so important about these temples that needed to be superimposed?

This is where its etymology came in very handy again, because you look at the actual language of the buildings of the church and it gives you a lot of clues. For example have

you ever wondered why you walk into that rectangular thing in the wall called an entrance? Have you wondered why it is called an en-trance? What is it entrancing? Why is it when you take these subtle devices including dowsing rods, you will actually find an eddy of energy at that entrance? Anybody can do this,. You go into all churches, even the one in Santa Fe, the Mission de San Miguel, which is built on top of an old Native Indian sacred space. Of course as you are walking through, your electromagnetic body is walking over this entrance and being entranced. Then, while suitably entranced you go down this long aisle called a nave, which in Medieval Latin was *navis*, meaning ship. You disembark at the other end of the nave, at the altar. What is the altar altering?

Why is it that there are all of these congregations of subtle lines of magnetism around the old altars of sacred spaces, even today? Why is it that all these altars, especially in Europe are all built on slabs of red granite, one of the most powerful conductive rocks on earth? For two very good reasons: 1) huge amounts of quartz crystal, and I'm sure many people are familiar with the properties of quartz and its programmable electromagnetic properties; 2) huge amounts of iron, the kind of stuff that you find in the blood of the human body. Makes you wonder if all of this wasn't done very deliberately, because it was.

A hundred years after Pope Gregory tries to prohibit using ritual power at sacred sites, something really bizarre appears in the

landscape, enormous cathedrals. Think about the time during which these enormous structures were erected. It was time when there was plague, famine, pestilence, massive wars; these are great social and economic indicators to start a building boom. It doesn't make any sense. Who in their right minds comes up with the money and the ability to put these incredible edifices throughout Europe?

If you follow this line of inquiry, you realize that the guys who put up the money for this incredible endeavor were none other than the Knight's Templar. We're talking about the people who originally had the secrets of the Egyptians mystery schools, because they were the Knights of the Temple. They kept the ancient Egyptian knowledge about harnessing subtle energy, about working with geometry and sacred measure. They knew all about resonance and its effect on the human body and its state of awareness.

So, building these magical structures is easily understood. It has everything to do with energy fields both physical and otherwise. These were the people that were responsible for encoding the information inside of these incredibly elaborate buildings. When you look at the time during which these events took place, with the Holy Inquisition, you realize that the Knights Templar and the Free Masons of the time were really up against it. Phillip the Fourth of France was wanting to exterminate the Templars. When Phillip's boyhood friend became Pope Clement the Fifth, together they destroyed the Knights. These stories are

in my culture. In Portugal we still worship with some of the traditions that the Templars had almost two thousand years ago. There are whole towns in Portugal that are still dedicated to Templars. There's a great veneration for this, in fact my country was the first one to actually create its borders in Europe and it was founded by the Knights Templar as they were running away from France. You also find the Knights in the De Vinci code, who end up in Rosslyn, but that's another story. I used to live next to Dan Brown. I'm still waiting for it to rub off on me. We both lived in Rye, New Hampshire. He's still there with a lovely house by the beach.

The Knights realized that one way they can maintain all these secrets is to encode the information right under the noses of the very people who are trying to get rid of them. So they put some knowledge of what they knew inside the actual buildings themselves. Today when you survey these incredible edifices, what you see is that the relationship of the walls, the pillars, the altars, everything relates one to another by the encoded array of geometry of harmonic, of sacred measure, and so forth.

What our Russian friends found out in the last few decades was that something very unusual happens in these buildings. When they strapped people up to EEG devices and stood inside gothic cathedrals, they found that when you stand inside specific shapes it has a very profound effect on your state of awareness. The rate of healing goes up dramatically inside specific shapes. An example is in Bulgaria, back in the 1960's. The Bulgarians designed rooms shaped like

pentagrams. They put sick people inside these pentagrams and found that the rate of healing went up dramatically. They also put schizophrenic patients inside trapezoidal shaped rooms and also found that the rate of healing went up dramatically.

Suddenly modern science begins to recognize that there is something about the influence of shape on the human body and its ability to heal. This is how they discovered that these places do alter you. These places have a profound effect on the human body. Some people began to realize that this effect is why great effort had been expended to prevent these places from being taken down, because they worked. These sacred sites have a profound effect on your state of awareness. Our Russian friends took this a stage further by the way; they began to also realize that the specific music that was used in gothic cathedrals in those days was Gregorian chant. When you play Gregorian chant inside the gothic cathedrals your brain wave patterns go up four-thousand percent, above normal waking state. Your antenna, your standing spine, is literally making you much more open to connect with other levels of reality. Some people will describe that as connecting with God.

This of course is painting a very broad picture. The fundamental resonance, the overall fundamental resonance at sacred sites seems to be very consistent around the world, so I am told. At each specific sacred site such as Delphi, Stonehenge and the Great Pyramid, there seems to be a fundamental frequency at work of about 7.8 kHz, which is very close to the frequency

that actually drives down brain waves to reach a point of receptivity. In other words, these places get you to be in a place where you can actually connect much more easily with other levels of reality. It makes you much more psychic and open. There is a definite technology at work at all of these places.

This is where the story begins to break down a little bit. If you imagine the amount of technology, preparation, resources and skill that went into building these incredible buildings, suddenly you realize that no matter where you go around the world every single sacred space, cathedral, even the Great Pyramids and the Navajo sacred sites in Monument Valley in the middle of the desert, are all built on architecturally unsuitable terrain. They are all built on water. You can't convince me that you're going to go to all this trouble to put these things on the ground and watch them sink. It doesn't add up, unless of course there is something about the sighting on water, which makes water part of this spiritual technology, allowing you to have an altered state of awareness.

We know a lot of things about water. It is very, very important to the conductivity of energy. Water is in fact a great conductor, especially when you apply the spin motion of energy. Magnetometer surveys that were conducted in Britain at certain stone circles have found that magnetic energy actually flows inside these spaces in a spiral pattern.

It is almost as if the energy itself was actually working like a big sort of sinkhole

into the ground but it also comes up as well. When you apply the spin motion of energy on water you generate an electromagnetic charge. Your body and mind, also being electromagnetic, come into contact with these spaces. Obviously there has to be an influence. There has to be an exchange of information between the sacred sites and your body as well. Let me take this a stage further, spin is nature's most efficient movement of energy. We take it so much for granted these days that when we look up at the heavens we hardly notice it anymore. When we walk on the beach many of us don't even realize that this motion of energy is the fundamental shape of nature. It is also so fundamental to us as human beings that without the spin motion of energy, blood cannot move through the veins of the human body. We would literally be dead without the spin motion of energy. It is all around us, especially when it comes to sacred sites around the world.

You see this understanding carved in sacred sites all around the world, specifically in the sacred sites of Ireland, which actually got the attention of a team of people from Princeton who were looking at the effects of sound and the state of awareness of people when they walk into these sites. What the team from Princeton discovered was that when you discover the right resonant note of a chamber you could actually find areas within the chamber, which when you hit a certain note point, a standing wave pattern arises inside the chambers, which meant these buildings were created as tuned resonant cavities.

What they also found was whenever they threw smoke inside these chambers, whenever they managed to find the right frequency of the chamber, spirals began to manifest in the smoke, literally in front of the places where these spirals were carved on the rocks. So our ancestors left us the instructions carved on these stones. They said that if you stand here in front of the spiral and you play a certain note of music you will be entranced. The instructions are there right in front of our eyes. We can begin to appreciate what these temples really were for, what they do for and to us.

There's a very rich history of healing, invocation and heightened states of consciousness at all of these sites around the world. The reason I go around this long route of electronic measurements to explain a very simple subject is because the spin motion of energy also happens to be the foundation of these brand new temples on the land, the crop circles. Every single genuine crop circle is always built on the foundation of this natural flow of spiral energy. This spiral of energy manifests itself in a way that plants are laid very firmly to the ground without any damage. It's a specific spiral of energy, the golden ratio. Every single genuine crop circle conforms to the spiral motion of the golden ratio. Basically, this is nature's own spiral of energy. We also call it the Phi ratio or the golden mean. It's not just the small circles that have this ratio, it's also the large ones.

The interesting thing is that throughout the twenty years of modern research of crop circles we have also found some

interesting correlations between these new temples, which is why I call them temples, and the old temples. We have 800 references of people having heightened states of consciousness in crop circles, many were skeptics to begin with and some of them are very, very left-brain people. A lot of lawyers, accountants, you know I haven't got anything against those people, it's just that it is very interesting when they start saying "I'm perceiving things, energy and stuff." These are very rational people. When they actually go to these sacred places, they were skeptics and they talk about that shifting, I listen. Those are the people I'm trying to actually bring into the fold, the ones that don't seem to understand or who have taken into being very physical, believing that this three dimensional object world is the only world that we have. Well, there's something else going on around us all the time.

The more miraculous part of this phenomenon is healing. We had hundreds of cases of people who have been healed as a result of walking through the crop circle, ingesting the seed from a crop circle, including a young man in New Hampshire not far from where I live now, who ingested the seeds from a crop circle and viewed the image of the circle for about month. He had a malignant tumor in his left eye. After the month he goes back to the doctor and the tumor is absolutely gone. A second person with bone cancer, she was sent home to die. She literally had a couple of days left to live. Through the homeopathic application of putting some spring water on an image of a crop circle which I administered to her

over the telephone and she's back at the hospital two months later. She drives herself to the hospital. She's supposed to be buried. Can we explain how an image of a crop circle can do this to a person? This is just to give you an idea of the potential of what's going on here and the connection to ancient sacred science. We're talking about one and the same thing.

In fact, a lot of the principles that you find in sacred space, as in gothic cathedrals, you'll find them also encoded in crop circles. We also have much evidence, brand new information, where we have discovered a four degree magnetic field shift inside genuine crop circles. We don't know why that is at the moment, but we do know that these things are listening to our thoughts or maybe they are giving us information. Only two hours before this four degree magnetic shift was publicly announced, and it was a well-kept secret, this design shows up only a few miles away from where the press conference took place.

It shows (Figure 1) how each one of these eleven segments has been rotated exactly four degrees to give you the shape on the ground. Someone was literally listening to our thoughts, or even feeding us the information. Perhaps they are trying to show us a new level of physics, a new understanding.

The time when 95% of the world's crop circles appear is between 2 and 4 AM. Well, this is very interesting because in the Royal College of Medicine in London a physician has discovered that 95% of the worlds

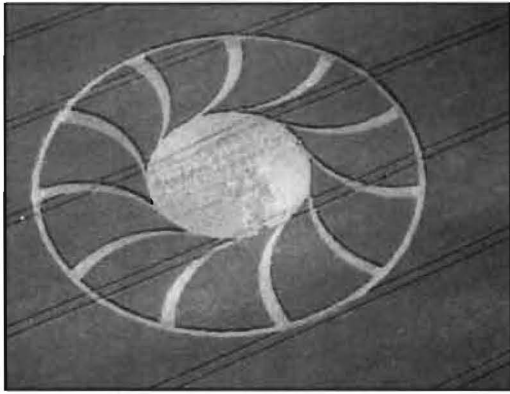

Figure 1. Four degree shift

reported deaths occur between 2 and 4 AM as well. So, it's as if what we've been shown here is an inter-dimensional window where we as souls are allowed to leave for this window of opportunity, but information can also come down as well. It's also a possibility that between 2 and 4 AM that point on the planet is where we are furthest from the sun. In other words the Earth's magnetic field is having a little sleep of its own. This again is new information. Take this where you feel it is necessary. Let's take all those expressions of energy, spiral motion, atoms and bring them all together. Very large expressions of spiral energy that we know today are planets. In the old days the planets were considered to be living beings. In fact, the Greeks called them the Akousmata, the resonant ones, sharing once again the veneration for sound as a creative force in the universe.

The ancestors recognized when they looked at how these gods travel around the heavens, that the mean orbits of the planets, that is the average of the eccentricity of the orbits of the planets, form ratios, each orbit of one

planet to another, related to each other, in this invisible glue. This is where the idea of sacred geometry starts coming into our lexicon, because the ancestors realized that these living, breathing gods were the perfection of all that there is in the universe. They are holding together this invisible array of geometrical shapes. So, the sages figured, well, if everything in the world of god is perfect, why not take that geometry and put it on the land. This is what the Egyptians did. They were the masters of encoding all this geometry into their temples. They did all of this to create temples where the harmonics were designed to create specific resonant environments, which would then transform anybody who was dis-eased with their environment and would allow a person to leave with the power of this environment, which is absolutely perfect. You come out as a whole new being. From here we have the word Holy also coming into our lexicon, very much like gothic cathedrals that came long after. The Egyptians also were working with a prevalent use of the Phi ratio, the golden mean ratio spiral, which is prevalent in all living organisms and also the human body and crop circles.

If you travel around the world like I do and you look at these sacred sites, one thing that you may notice is that they all appear to be very strategically oriented on the land. These people had an unnerving ability to put their temples exactly in the most beautiful elegant location on the landscape. This to me and to many people before me suggests that there was some kind of referencing taking place, as if there's some kind of underlying force or some point on

the land that was being specifically registered. The same thing is seen also with the Neolithic architects, people who basically dispensed with ornamental temples. They went around to the top of the hill and said, "Hey let's take down this three hundred ton boulder. Let's roll it down the hill, bring it over a stream, a river, a dale, and then we will put it upright in the middle of nowhere." Again, it made me wonder, why do they do this. There is some kind of referencing taking place here, something marking something. It was a lot of trouble to move these rocks. Why did they do this? The naming of these sites comes to our rescue, because in Iberia they called these sacred sites by two different names, one is Betilo, which comes from Semitic word Bethel. It means house of god. So we're back to house of the lord connection.

Then you go over to the northern Iberian peninsula where they call these things Anta, which comes from the Latin *annotare*, meaning to mark or to locate. What are these things marking? What are they locating? In light of the work by archeologists, dowsers and people who work with subtle energy, many of whom are at this meeting today, they have discovered over the last 50 years, at least, that every single one of these sites, with out exception, mark the cross roads of invisible yet measurable pathways of magnetic lines of Earth energy. They literally mark these spots. This is where lines congregate. Subtle magnetism generates itself at these lines and something holds them down to that position so it never ever moves. There's more to it than that, because it's not just these invisible lines

of energy on the landscape. It's the fact that the energy also flows out and looks like ripples across the land. This is an energy map that I made of that particular standing stone. (Figure 2)

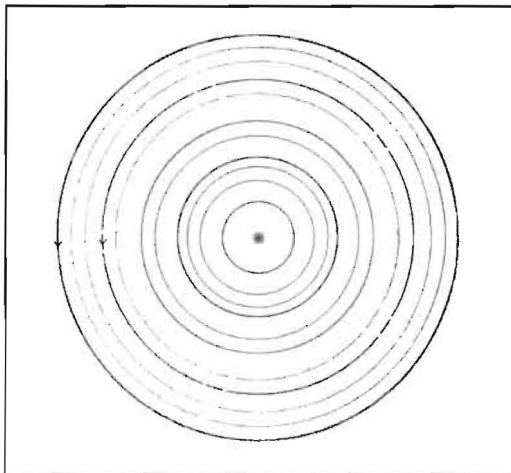

Figure 2. Standing stone dowsing ripples

I've done this for Stonehenge; I've done this for cathedrals. I go around the world measuring the ripples of energy that emanate around sacred sites. What I've discovered is that every single one of these places are energy hot spots. It seems that each one of these rocks, each one of these altars is holding this emanation of energy, which ripples along the landscape. But what is unusual about the location of these ripples is that each one of them is very strategically located on the land. These ripples contain structure. The spacing of each ripple of energy from the center of any sacred site conforms to the harmonics of an underlying geometry. This geometry tends to be either clumped into pentagrams or hexagrams, which are very sacred geometrical shapes which you'll find again and

again in sacred sites around the world. You should consider the work of Guy Underwood, a very famous guy who also gave up his day job to follow his obsession. His obsession was why are these churches exactly where they are and why are they superimposed on sacred sites? Underwood's work clearly shows that the positioning and the walls of this building, exactly matches the underlying effect of magnetic forces already on the land. This is in Salisbury cathedral in England.

The faded lines you see here (Figure 3) are the two Dragon Lines that cross that particular part of the landscape in Salisbury on what used to be a marsh. In fact, if you lift up the flag stone floor of Salisbury cathedral you probably find running water about 4 feet below it. The buildings are literally floating on water. It's an engineering marvel. You can see how the actual cruciform shape begins to take a completely different meaning. Look also where the nave intersects. You can see how in the center there are all these ripples of energy which are now emanating out of the building as well. These irregular darker lines that you see here are underground veins of water, subsurface water.

You begin to appreciate why the entrances are exactly where they are. Look at the way that they

follow the actual contours of the building. Whoever built these buildings knew exactly what was going on under the land. So the super imposing takes advantage of these underline forces of energy. Of course the effect on the people who go into these spaces is very dramatic indeed. It's the same with pyramids as well. This is the reason why the pagans' sites were assimilated and people were building on top of each other from era to era to era. They were marking these very important points on the landscape. Which definitely alter us and create the space to really create very miraculous things. So far we've made a common thread here.

We have a common thread, brings together sacred geometry, magnetism, and sound. We have the spin

Figure 3. Salisbury cathedral energy lines

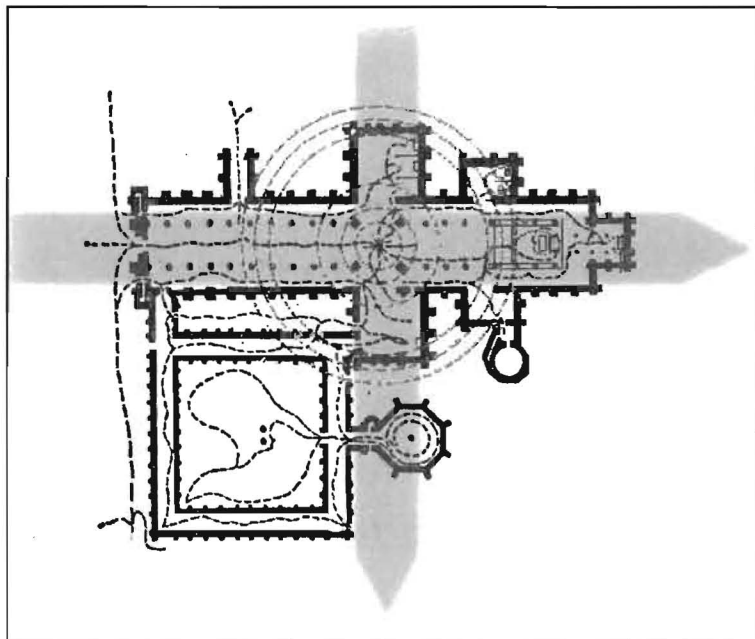

motion of energy. We even have water. All of these things are creating a resonant effect on the human body and anybody that enters these spaces. We are talking about the places which provide an environment that alters your state of awareness and brings you closer to an actual realm of god or the spirit world. This is where my story takes a very dramatic turn. This is where I had to quit my day job. I suddenly realized there's a very profound connection between these brand new temples of the crop circles and the local sacred spaces. No matter where you go in the world, in twenty-nine countries around the world, even here in North America, on the Great Plains, Saskatchewan and Alberta, you'll find that the crop circles always appear beside ancient sacred sites. If you don't believe me, when they appear on the world wide web and you find one in Saskatchewan where there's nothing but wheat fields around this crop circle, go back to about 1890 to the local church records of the first settlers. You'll find that soon after they moved in, the local farmers tore down the local Native American sacred mounds. You'll find that these mounds are only a few hundred yards away from these brand new temples.

The story does match, these people, these beings are trying to give us some kind of connection. As I said before, there's a wonderful connection between the people who actually go into these new temples. They, too, experience similar physiological and psychological effects. I'll give you a good example with the world's biggest stone circle. In fact it is three stone circles. It's

Avebury in England. Because it happens to be in England, of course, there's a pub right in the center. We call it a research facility. It's kind of interesting because the shape is this wonderful spider's web. The spider's web in traditional folklore is a symbol of the moon and lunar worship. Up until today it is the lunar worship, the female principle, which is actually venerated at Avebury. You'll also find that there's a magnetic line of energy which goes through the stones of the second stone circle. There are only three stones left standing now in the second circle. The energy line flows right through the center of the design, so all three circles are energetically linked as well. The story goes that when the Puritans decided to take down the stones of Avebury, because it was a place of the devil, they built the houses of the village of Avebury with those stones. So after that the houses began to spontaneously combust. So it seems that the devil got his own back on them. If that wasn't enough, the houses that remained standing, the furniture in them would rot, because the stones soak up water. The devil is really naughty, very weird.

Iwould like to give you a brief scientific excursion on this phenomenon. This really is what it's all about, this is something that plant biologists, and people who work with natural principles are scratching their heads over. What kind of energy can do this to plants?

What you see (Figure 4) here is a plant from a genuine crop circle. You'll see that it is not damaged. It's bent just above the soil as if something has made it very molten,

like glass. It's re-hardened in its new horizontal position. If you're a gardener and you pull any weeds or plants from the ground, you'll also appreciate that the roots are geotropic. They go down and point to the center of gravity, which should be at the center of the earth. What we find is that

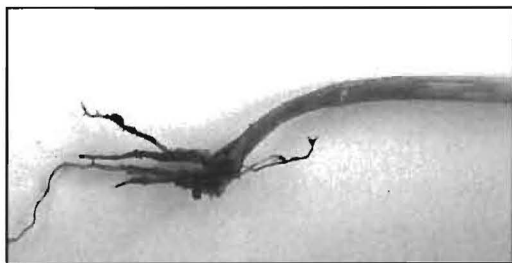

Figure 4. Crop circle plant stem and root

with the plants from the genuine circles, the roots are pointing in the wrong direction, suggesting that the local gravitational field has been tampered in some way as well. This is all new stuff. We have discovered through magnetic surveys that not only is there detectable electromagnetic energy which bunches inside the flattened areas but also that there's a magnetic print of energy which stays up to five years, long after the physical design had vanished. That magnetic signature very much conforms to the actually area of a flattened crop. We have also found that by taking a sample of wheat under the microscope and comparing them to normal wheat, the sample that comes from a crop circle shows there's a great deviation in its crystalline structure suggesting that the energy involved is altering the crystalline structure of the plants themselves. (Figure 5)

Yet, the plants are not damaged in any way.

That's the miraculous thing about it. The other incredible thing is that the soil in genuine circles has been super heated to 1600 Celsius in a fraction of a second, which accounts for a lot of the charring of the plants and also for the dryness of the soil. It's very weird to go into a crop circle, especially in England where once in a while it does rain. You walk toward a crop circle if it's been raining heavily over night and the soil is sticking to your boots, but when you get into the circle, you pick up some soil and you can blow it off the palm of your hand. It's bone dry. If this energy is having this effect on biological systems such as plants and soil, you can begin to imagine the resonant effect on people who come into contact with these spaces, particularly

Figure 5. Wheat sample micrograph

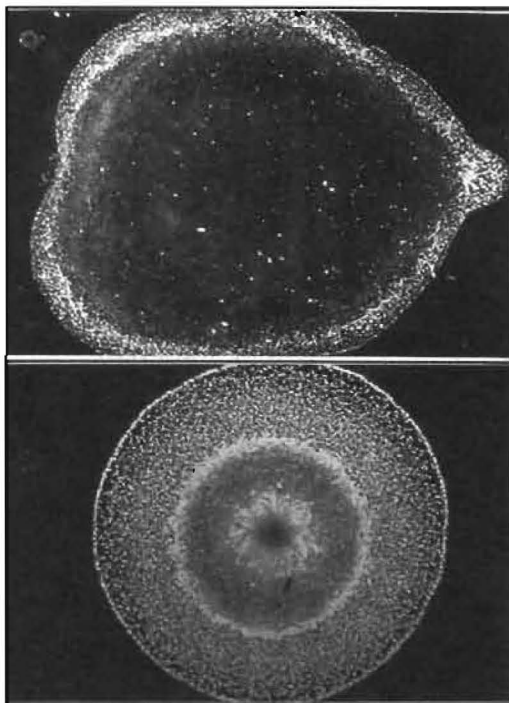

since we have lots of crystalline structure in our bones. Also, bones have a lot of built in genetic memory that comes from our previous ancestors. This memory is harnessed and hardwired right into the bone. So what is that crop circle energy doing to us as well?

My good colleague Gerald Hawkins, who passed away years ago, wrote *Stonehenge Decoded*. He was the first person to discover that there is very highly specific information encoded inside the crop circles. Specifically five brand new mathematical theorems, which should have been in one of the sections of Euclid's thirteen books on mathematics. Euclid was the Greek mathematician from about 300 BC who basically formed a foundation of mathematical understanding. As Gerald said to me, "You know there should be a little gap in his books where these theorems from the crop circles should fit." Euclid could have easily figured them out. But the circle makers appear to have jumped one step ahead and put them in there for us. It's very difficult to create a mathematical theorem. As Gerald said to me, "It means that maybe 0.1 % of the entire population of the earth would be making crop circles." Which means maybe university professors could be doing this. Even as badly paid as university professors are in Britain, he said, I don't think that they are moonlighting making crop circles. Much easier to get a piece of paper and a pen and do this theorem right there.

Figure 6 is one of his works; this is actually Ptolemy's theorem of chords. I've spoken

to tens of thousands of people around the world and so far only one person has put their hand up and said I know what that is. Even he said that's a bloody hard theorem. Especially when you have to do it in the middle of the night with planks of wood and strings. It does show that the intellectual profile of Templars, Freemasons, whoever or whatever it is making

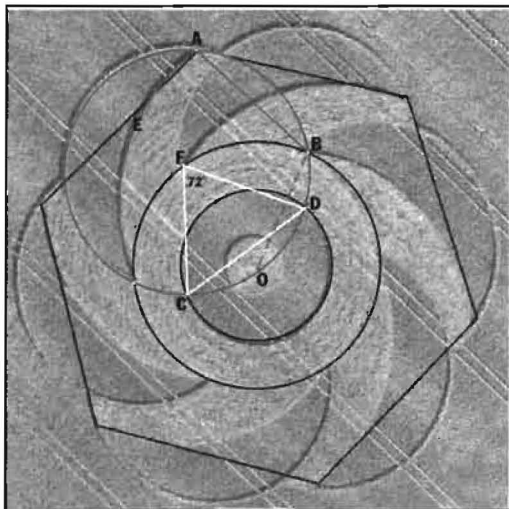

Figure 6. Crop circle with Ptolemy's theorem of chords

these crop circles is very high indeed. We also have specialist knowledge that's miraculously encoded in these designs because in this particular example, two near identical patterns appeared in the same evening. (Figure 7)

If you superimpose these two crop circles there are slight discrepancies between them. What a group of physicists discovered was that these little discrepancies, these numerical discrepancies give you not one, not two, but three speeds of light. Ten years

ago orthodox science said that's not possible, there's only one speed of light. Well five years later they discovered a second speed of light. So whoever is behind this is not just one, but two steps ahead of us already. The reason why I put this out is to show that there is information that lies below the surface of these temples. It is

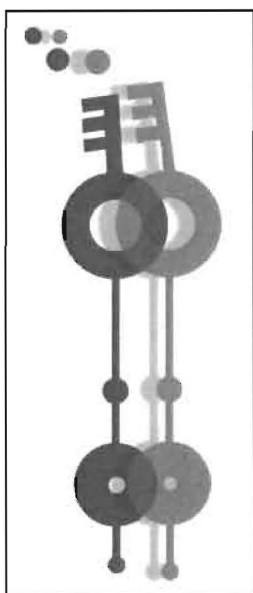

Figure 7.

worth looking at it. It's almost like what we are looking at here is the encoding of specialist information just like in the gothic cathedral.

Now the affect of the crop circles on people perhaps has to do with the encoded geometry of these designs as well. You may wonder, has this guy completely lost the plot. Where is the sacred geometry in

this crop circle? (Figure 8, 9)

Because it's just a straight line with a bunch of circles and some rings. Well, take another look at what actually holds that design together. The positioning, the flattening of all of those samples of wheat. The diameter of each circle. The thickness of each line. It is very precise. That's actually what your subconscious is picking up on in the crop circle. The darker shape is actually the physical shape of what you and I are picking up in ourselves. It's all

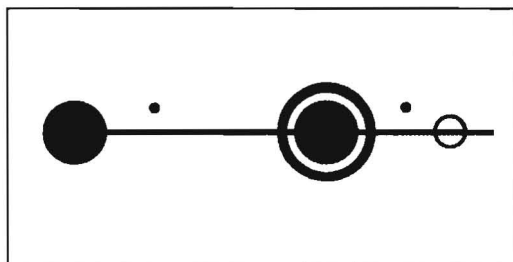

Figure 8. Healing crop circle

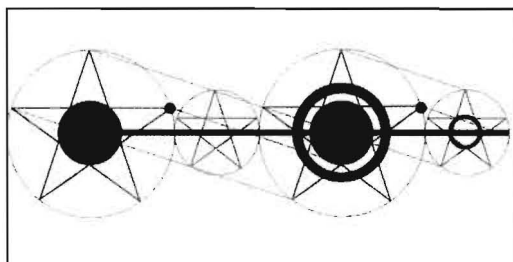

Figure 9. Circle With underlying sacred geometry

this stuff in the background. I'll show you another example. This is by John Martineau, a wonderful geometrician. I always get the feeling that he's the reincarnation of Johann Kepler, an incredible mathematician. This is another design, a basic Celtic cross design. (Figure 10, 11)

It also looks like the electrons going around an atom. Notice the tiny little circle outside the large circle, above to the right, out in the field. Many years ago a good friend of mine called Isabel Kingston, a wonderful channeler and accountant as well, accidentally vectored information from the origin of the crop circles. It is a good use of the left and right brain. I read very curiously about them saying keep your eyes on the little details in the middle of fields. This is

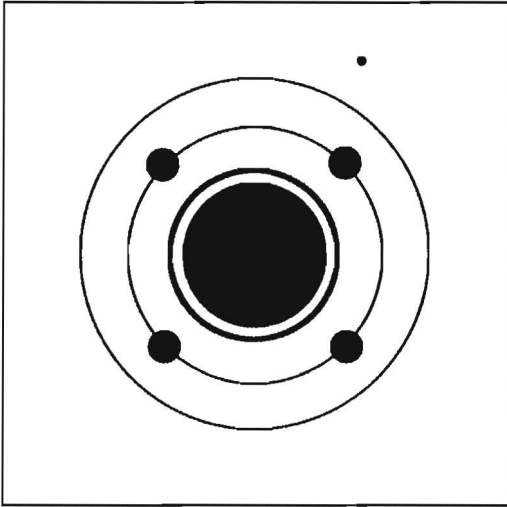

Figure 10. Harmonic crop circle

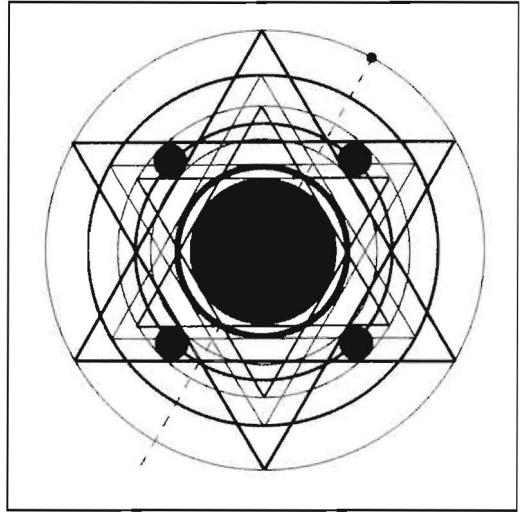

Figure 11. Key to blueprint for harmonic crop circle

where it got our attention, because when you look at those little circles in the middle of nowhere, when you actually put a straight line in the center of the design it gives you the blue print of what holds those lines and those circles together. Again there is use of pentagrams and hexagrams, these special relationships, these natural harmonics which are fundamental universal principles again, at play in crop circles as there was once in gothic cathedrals. Here's another example of sacred geometry, a pentagram with two pentagrams. (Figure 12)

Thirty-six people expressed healing in this crop circle alone. All of them unrelated to each other. Also a Japanese group of tourists who came in with video cameras, thirteen of them put their camera down on the ground. The cameras never worked again. As a professional photographer for many years I can tell you that just doesn't happen unless of course there something electromagnetically going on which is altering

the crystalline structure of the motherboard of your equipment. When you go to Britain make sure you don't put your cameras on the ground. Trust me I've lost three Nikon's already. A very expensive phenomenon.

The effects on the body are like a cathedral as well. People go into to these spatial relationships and they have the same profound effects. I began to take the same curiosity to crop circles as I was doing in sacred sites. I realized that when I began to look for energy fields around the crop circles they were there. To my amazement they looked exactly like the ripples of energy around the standing stone, or the altar or the cathedral. In this particular design, I'm going to have to do some geometry of my own. (Figure 13)

There are these four ripples of energy you can see here around this physical crop circle, but when you look at the picture on the right, again, when you extend the geometry

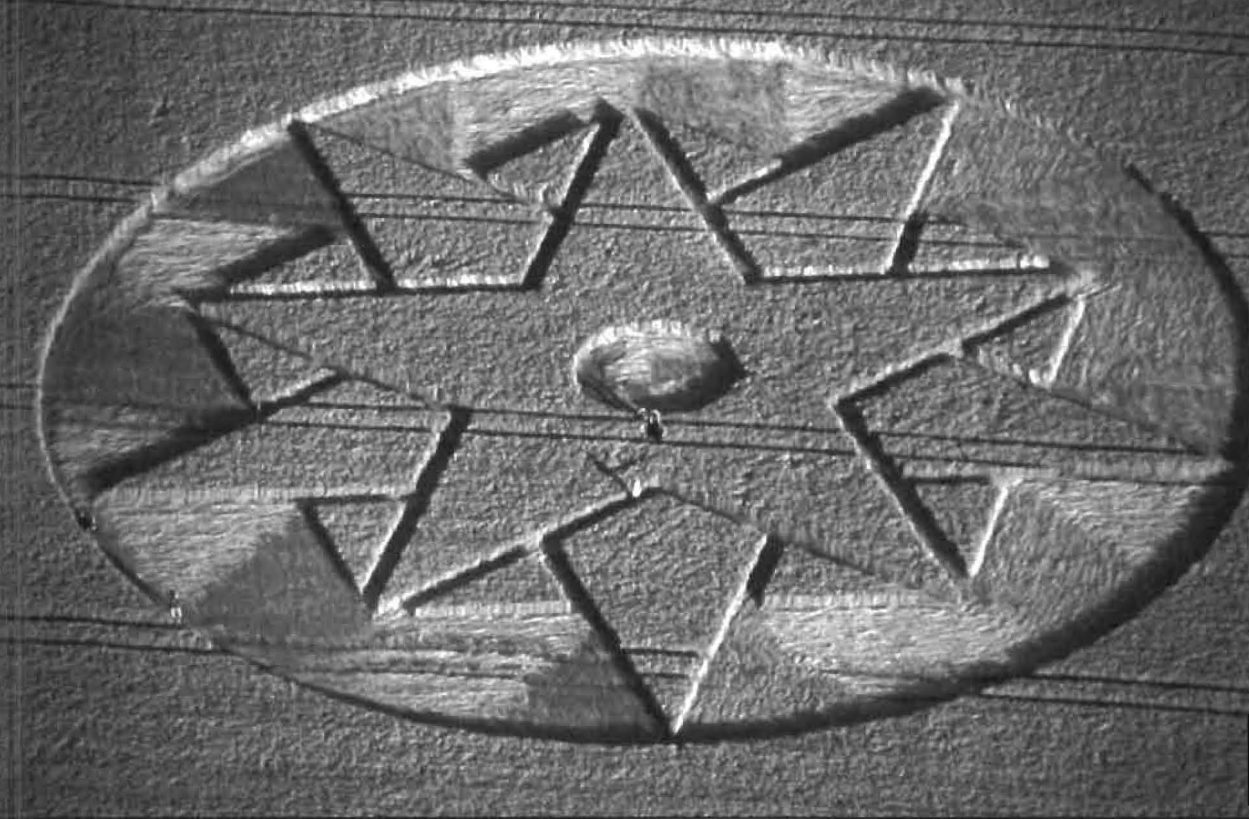
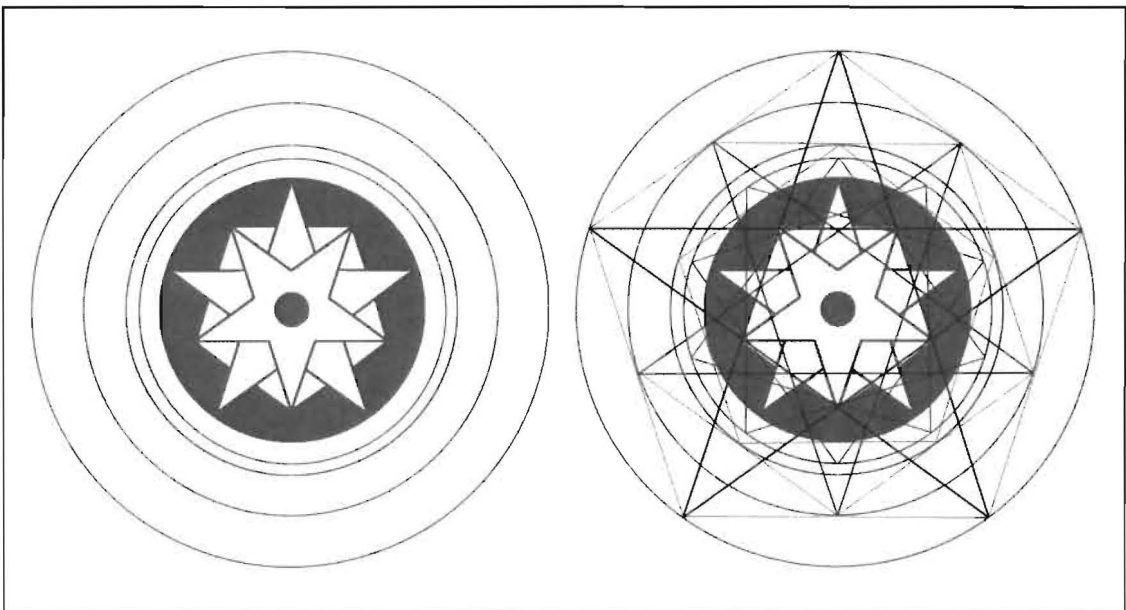

Figure 12. Pentagonal healing crop circle

Figure 13. Dowsing ripples from pentagonal crop circle and underlying sacred geometry



of the flattened area of the crop, you can see how that geometry when it extends itself to its natural point, it hits exactly where those ripples begin. So what you're seeing here is that the physical shape is generating its own energy pattern as well. The implications are very profound, because you're no longer dealing with merely a shape. You're dealing with an organism. It's alive, it's breathing, it's sending out information and energy across the land, and all of these harmonics are generated by the physical geometry. You can do this observation one after the other. The energy field doesn't just ripple across the land though, it also goes below the ground as we discovered from magnetic surveys. And it stays below the ground for a considerable amount of time. We began to appreciate these very distraught complaints from helicopter pilots

that were flying over the crop circles. At specific times of the day they would suddenly complain about a very agonizing array of red warning lights on their instrument clusters, compasses suddenly pointing South or Gyroscopes behaving in a most drunken fashion. Now they no longer even fly over crop circles. We began to appreciate that these things are not just flat, they are three dimensional, because the energy field goes above them as well as below. These are real three-dimensional organisms. They are living and breathing on the land.

So we can begin to appreciate that crop circles aren't just pretty patterns. They are a type of temple, a type of new Gothic Cathedral if you like. Then we begin to appreciate that the genuine designs, and only the genuine designs, are also just like the local sacred spaces and the Gothic Cathedrals, which also appear at the crossroads of magnetic lines of Earth energy, without exception.

Figure 14. Energy intersection setting circle diameter.

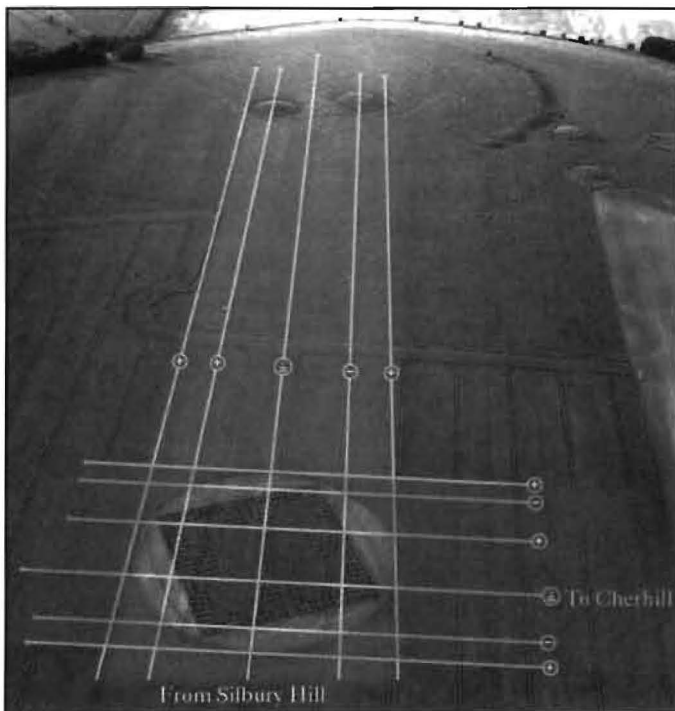

Figure 14 is a good example of how two intersecting lines of energy generate the diameter of that crop circle, which itself is also linked to the local sacred space at Windmill Hill, a very old Neolithic Settlement, circa 3500 B.C.

Another example are these sacred mounds. The implications now are very profound because when you consider how I started this lecture when I spoke about how the sites were shut down for many thousands of years because

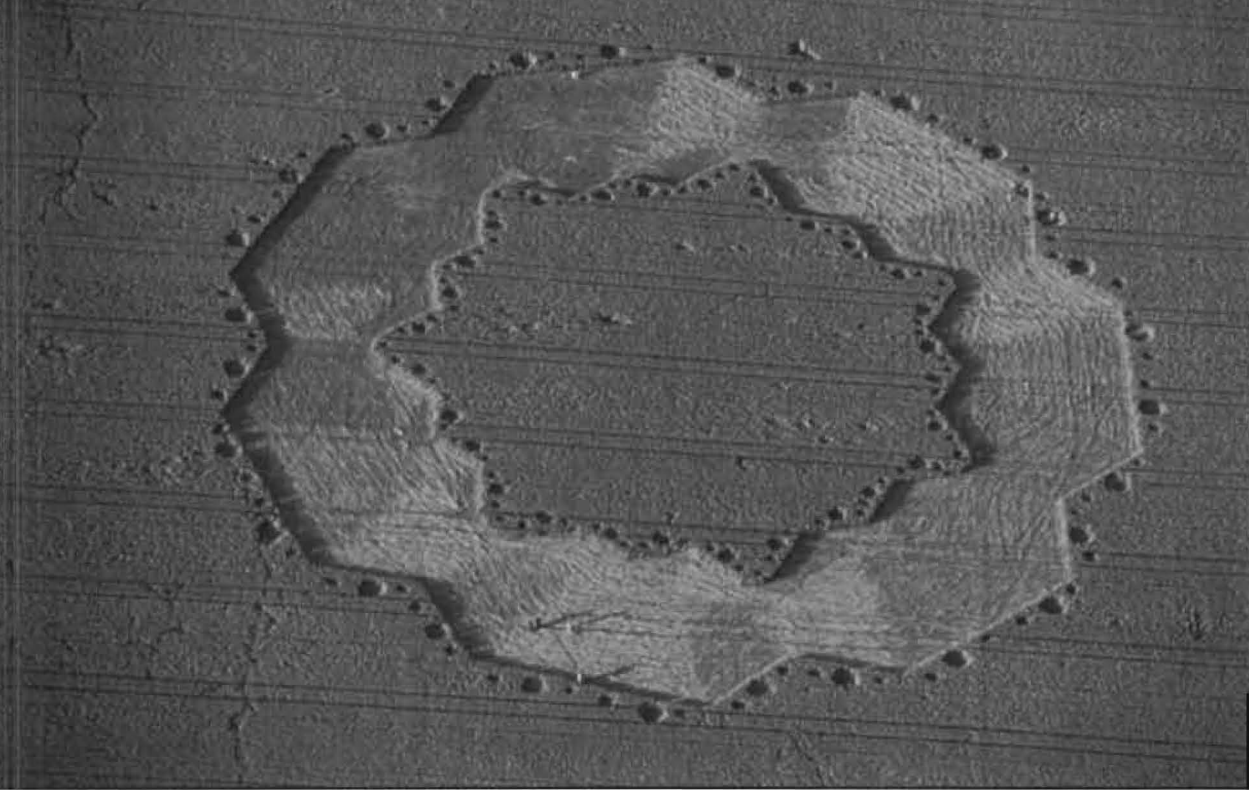

Figure 15. Heptagonal audible crop formation

of abuse, well, now people are going back to these sites and they feel that they've come alive. I just wonder if these organisms and all of this energy and information are imprinting something on the Earth's magnetic cassette tapes. That's how I call them. These things are cassette tapes. They're sending their song to these sites and they're beginning to wake up once again.

One common denominator we find in the altering of human awareness in temples comes with the resonance created by the sound at these sites. We know that sound is very, very important. No matter what religions disagree on, the one thing they do agree on is that sound was at the beginning of the universe. In the beginning there was the Word, and the Word was with god,

according to the gospel of John. Same thing in the Koran. Same thing in Celtic mythology and so forth. They agree on that. In fact Hindu science and philosophy are based on the understanding of vibration, and it is expressed in the phrase Nada Brahma—Sound God. So I thought, as a failed musician by trade, I thought why not find out if sound really is behind the crop circles, or at least one of the formative principles behind crop circles. You know, if you can't beat God, you might as well go and emulate it.

The clues were everywhere as I began to find out. In this particular example there were two witnesses. We actually recorded audible notes inside this pattern. (Figure 15)

Not unusual perhaps, but the shape itself, the seven pointed star is analogous to the pure music scale, the seven notes of the piano keyboard and the “do-re-mi.” So when we heard these sounds, we put them on tape, took them to a local music shop and sure enough, they actually conformed to something like F, G, C, repeated over and over and over. And at a very, very high pitch as well. Suddenly I thought, OK, we’ve recorded music in a crop circle. When I got home, I went down to the library and asked the librarians “Do you know anything about sound, music, geometry, awareness?” They were rubbing their hands with glee saying, “We’ll have to go to the Library of Congress for this.” They sent me this book on the geometry of music. Of course I always hated geometry, I never liked the stuff in school to begin with and here I am having to do it. The book opens up to this page where this diagram sits. (Figure 16)

It is the construction diagram for that crop circle, which is part of a Greek myth called The Web of Athena. The Web of Athena shows how the heptagram, the seven-pointed figure, is connected with all of these lines. Except it’s an illusion. There are only three lengths of line, which are shown here by the three lines in black. The story goes: If you take those lengths of line and put them on a stringed instrument, you can play the notes. It connects you to the world of the gods. I took those three lengths of line and put them on my guitar. Lo and behold, I got back the same notes that I’d heard in the crop circle. So now hairs are standing up on my head. What we have here is geometric form as a harmonic expression of

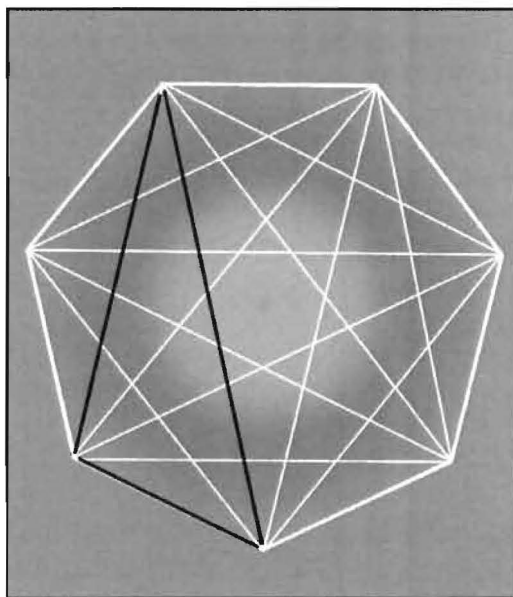

Figure 16 Web of Athena

vibration. Then I went back to my dowsing maps of crop circles with all of their ripples of energy that extended up to a quarter-mile and sometimes three-quarters of a mile around the physical design. I noticed that there was a relationship between the edge of the field of energy, and the beginning of the crop circle itself. (Figure 17)

In this case the relationship between the physical and the unseen is a perfect equilateral triangle. Mathematically, that’s a four to one ratio. Musically, that’s a double octave. So even the energy field is talking music and sound as well.

Then one day the circle makers decided to do something very unusual. Every time they don’t put the plants flat on the ground, which is very, very rare, they bend them six inches below the barley heads, as in this case. (Figure 18)

Try hoaxing that one. The first time that this happened Gerald Hawkins said “That’s unusual, I wonder what’s here?” And that led him to discover the first mathematical theorem in a crop circle. I thought, “What is this. I’ve seen this picture before.” What you’re looking at here is a Cymatic pattern. Cymatics is the study of sound as it penetrates liquid mediums, or any physical medium for that matter.

What you’re seeing here (Figure 19) is the image of a sound frequency captured at 1/10,000th of a second by a strobe camera. Notice the shape. When I discovered that there had been a man who had been similarly obsessed with sound in the 1950’s and 1960’s, I began to look at all of his work. He was Hans Jenny, a Swiss scientist, who passed away in the 70’s. He created his own laboratory and began to experiment

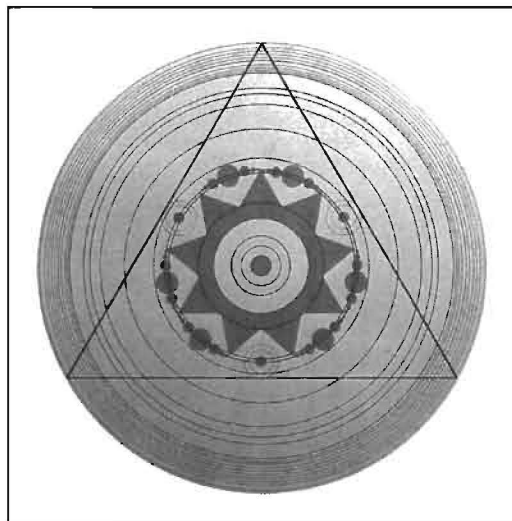

Figure 17. Dowsing perimeter with double octave crop formation

Figure 18. Crop formation with stems bent six inches below the seed heads



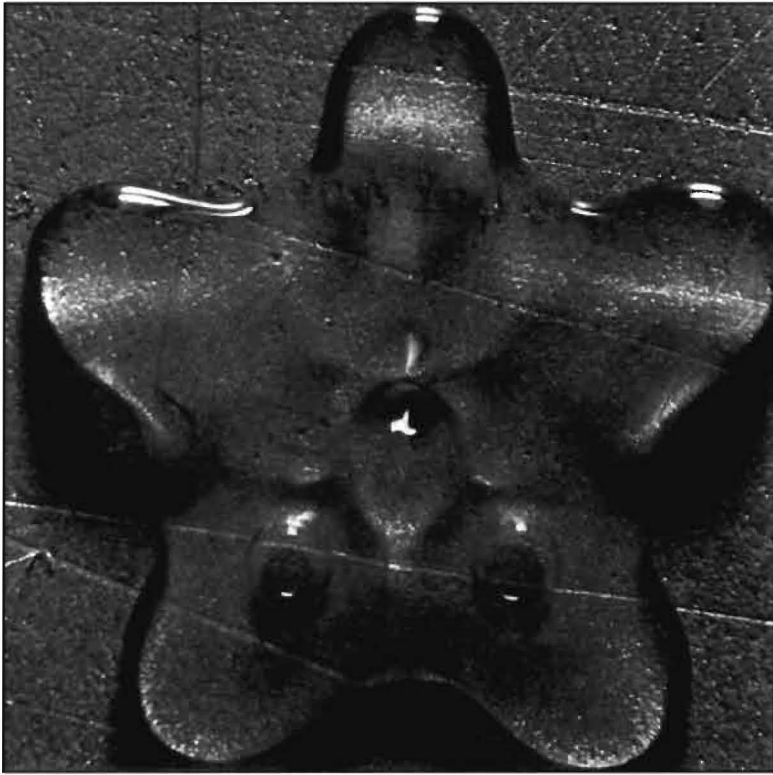

Figure 19 Cymatic oscillation captured by camera strobe light

with audible sound and in-audible sound in all its forms. He found that whenever you threw simple sound frequency and amplitudes through water, you can get patterns like this. (Figure 20)

It's very close to the Buddhist mandalas. And this is where I suddenly went "Oh, Suzanna, where have I seen this before?" So I began to take a very deep interest in Jenny's work. As I said, Jenny had passed away. I thought, "drat, I have to find out who has the information, because his slide library must have been intense." So I finally found that the guy who inherited this Swiss scientist's library of slides and information was only five miles away from me in Portsmouth, New Hampshire. I'm not making this stuff up. So

I thought, "OK, I'm quitting my job now, I'm going to do this."

Someone said to me, how did you, in advertising get involved in this? And I said "I don't know." He said, "What did you do?" I said "Oh, I was an art director, and a writer," and he again said, "Well, what did you do?" And I said "Well, I would take forty pages of written information, I used to condense that into a symbol or a headline and I'd sell that to a skeptical public." And then he said, "So what do you do now?" "Well, I take a symbol, I extract forty pages of information, and I still have to sell it to the skeptical public." I just don't get that much money anymore, but the fringe benefits are great.

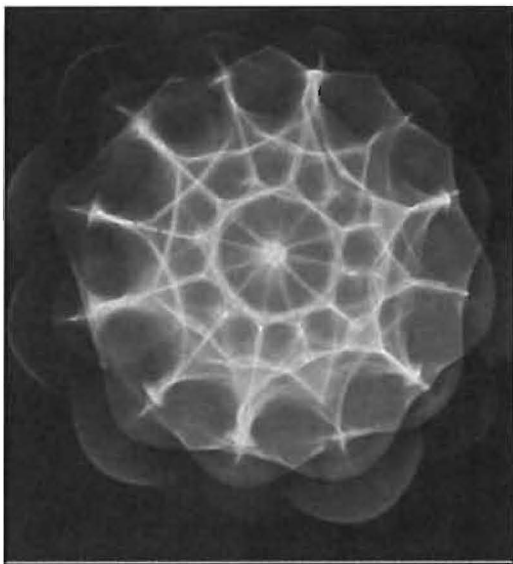

Figure 20. Hans Jenny cymatic sound mandala

So when I began to look at Jenny's library of information, I began to realize there was an unmistakable visual relationship. For example, Jenny was getting tetrahedrons in water, we're getting tetrahedral crop circles. We are getting six-pointed star fractal crop circles. Jenny could also get fractal hexagons as well. So the connection definitely was there. And this was the point I began to realize what is the connection between these and the human body. Why are people having these incredible levels of experience inside the crop circles? It's not just physiological. It's not people making stuff up.

When I began to take a look at the work of Valerie Hunt and her book *Infinite Mind*, it told me a lot about how the human body is mapped out. We are all electromagnetic beings, we are all in a state of vibration. And what Valerie helped me

to understand was that the body with all its myriad bones and structures, eyeballs, livers, everything, they all have a frequency. And she mapped things out. But what she found very unusual was that there was a big gap in our body where nothing happens, a great big blank. And this frequency range was hovering in the range of 250 to 320 Hz where nothing happens in the human body.

And this set of numbers brought to mind the work of a very young man, a skeptic in England, a computer designer called Paul Vigay, now a good friend of mine. I called him up and said "I have a series of figures here which seems very familiar to me, Paul." And he said, "I've been following your work as well for a bit. And it seems to me you can answer for me something that I've been discovering." What Paul had been doing for the last ten years in Britain, he went around measuring the energy fields of crop circles, as a skeptic. He thought the whole thing was a joke. But he realized something when he walked into the actual space of a genuine crop circle. He was measuring the electromagnetic background frequencies of everything – a field, a truck, a person, a goat; they all have a certain background frequency, because we're surrounded by this big electromagnetic soup today. But the moment he crosses the perimeter of a flattened area of a crop, his meter readings shoot through the roof. And he was getting a certain frequency range of meter readings that he could not explain. So we thought, "OK, well let's get together." And I said "Well, aren't you in England", and he said "Yea, where are you?" "I'm in Portsmouth, New Hampshire", and he said, "that's funny,

I live in Portsmouth, Hampshire.” He says to me, “Which street do you live on?” And I said “Orchard Street,” and he said “Oh, I can see Orchard Street right outside my room. You better come over.” So I booked myself a plane ticket immediately.

So we got together, put our things on the table, and I went “Oh, my god, what have we got here?” I was showing him what I found from Valerie Hunt’s work of the missing frequency range in the human body—250-320 Hz. He gives me the frequency range of what’s happening inside the genuine crop circles—260-320 Mhz. Suddenly we realized that these temples are having a profound effect on people because they’re filling in a frequency gap that doesn’t exist in the human body. And the discovery was very, very profound for both of us.

Now, I wanted to find out what kind of sounds could actually do this to plants to make them lie down horizontal in very unusual shapes. A woman named Dorothy Retallack put several plant species in controlled chambers and she would play for them Mozart, Led Zeppelin and the music of a very interesting sitar player called Ravi Shankar, the father of Norah Jones. She found after taking the measurements of these plants that when the plants were administered classical music, that they began to lean towards the speakers and to grow a little bit faster compared to the control samples. The plants that had Jimmy Hendrix and Led Zeppelin tried to run away from the speakers. In fact some of them were actually dead. But in the controlled chamber where the music of Ravi Shankar had been playing,

the music of this wonderful Indian sitar player, the plants had the stems actually bent in excess of 60 degrees to the vertical. The closest any human being had actually come to replicating a crop circle. I wanted to know why? What is it about this guy’s music that can do that to plants? Well Ravi plays Indian devotional music. Indian devotional music and its written counterpart, Sanskrit and also Ancient Hebrew, are traditionally supposed to be the vestiges of the words of God.

Sound definitely has a profound effect on the way plants behave, especially ultrasound. When you look at sound above the human hearing range, it can create the very things we see in the fields. The higher the frequency of ultrasound, the greater its ability for increasingly complex shapes. And we find in the fields in England, and throughout the world that the higher the frequency in the crop circle, the more complex the pattern that comes out of it. So we have a match here that matches its historical frequency throughout the fields. This reminded me of a very early crop circle which started out their era as simple circles and rings as well. Jenny also found that when he heightened the amplitude and frequency of sound, he could get patterns like this. (Figure 21)

Ultrasound can be focused just like a light beam, a laser. So you can actually create a very fine detail. To the point where you can make the molecules of any substance move within an inch and leave the molecules of the next substance completely alone.

You have these very thin radials that go

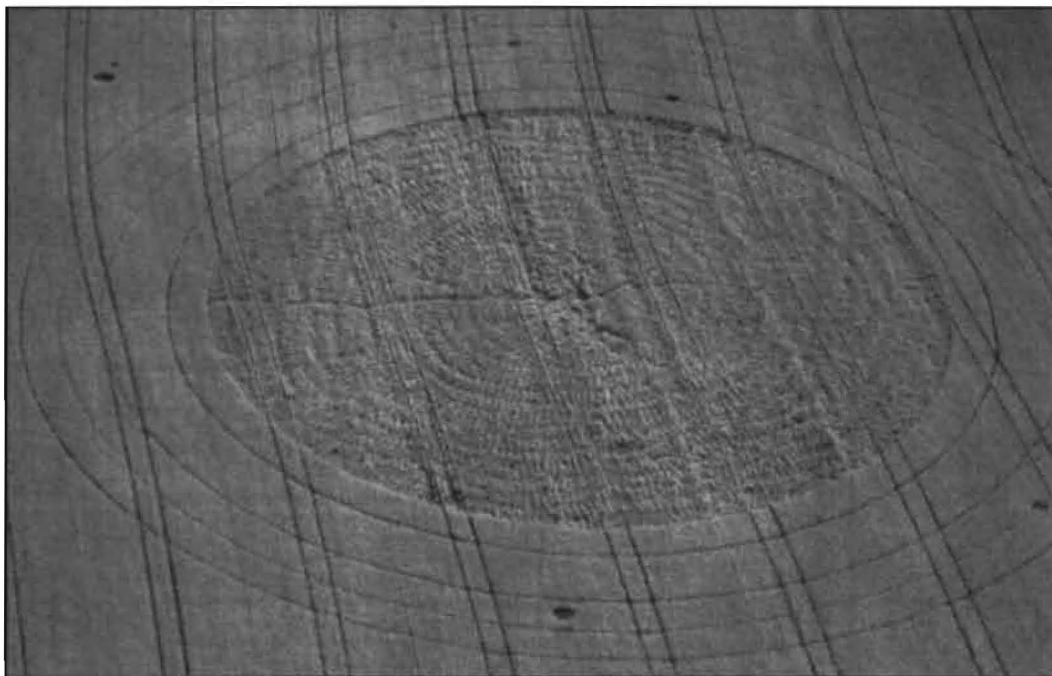

Figure 21. Early crop circle similar to cymatic pattern

around this crop circle, which are 800 feet in diameter. Two to three wheat heads apart. You can't even walk a small child sideways and create those kinds of ripples. But look what's happening here, in the center. The plants that were originally flattened to the ground, after two weeks of being left alone, because the only human involvement you'll see here is where people have actually taken plant samples, and soil samples and they've walked back out again. The rest has been left completely alone. The plants have risen back up to the light, but they've done so in a very curious way. They have actually risen in groups.

If you're on the ground it actually looks like a sine wave. And this is the ability of ultrasound to make the nodes of the plant

rise up, systematically, on the first node, the second node and the third node. That's what creates the shape. You can also see if you look closely, there are about 96 radials that extend from the center outwards. Now that's very, very fine detail.

A second thing about ultrasound you should know is that the megahertz frequency range on which it operates effects brainwave patterns. No wonder people are having interesting altered states of awareness in crop circles. It's affecting your ability to think and it drives your ability to be logical over to your intuitive side. There is, in fact a lot of evidence to show that in EEG devices that there is a great shift from left-brain activity to right-brain activity in crop circles. They are trying to get us to stop

thinking and start feeling. Which is kind of ironic now that I've spent about an hour discussing all of this. But there you go. The other thing about ultrasound is that today we know it prevents damage to sensitive tissue, which is why it's been used in hospitals more and more. So again the connection to healing is very appropriate to crop circles too.

Now at the other end of the range, we have infrasound. Sound below the human hearing range. And at this range, sound begins to disrupt physical substances. In fact it will alter chromosomes. Here's a very good example of a control sample of wheat under the microscope. (Figure 22)

Compare to a sample from a crop circle, which shows that the chromosomes of the actual wheat have been radically altered.

That's the power of infrasound, to actually interact with physical substances. But this is the real crux of the matter, because infrasound has a very incredible acoustic capacity. When you have high amplitude it moves through water at a very rapid pace. And when it does so, it can actually boil water. And this is an example, a very dramatic example of a genuine stem from a crop circle. It shows the dramatic heating at the base, the scarring from the heating. (Figure 23)

It shows a dramatic bending of the node, and an elongation of the node, and again charring. And when you make a cup of tea, you know how the water in the kettle needs to expand outwards. The same thing

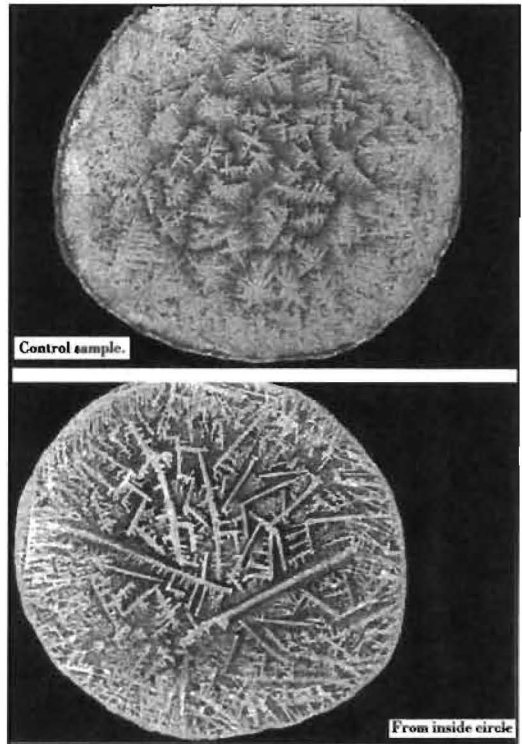

Figure 22. *Wheat altered crop circle*

happens inside the plant stem. Because inside a closed environment like a stem, the water has to look for a point that is vulnerable, in order to escape, because it's super heated it has to get out of there. What you'll find in the genuine crop circles is that there are little holes in the nodes where the water, the super boiled water has blown itself out. And the water blows out of these little holes and suddenly, according to eyewitnesses around the world, who've actually seen the crop circles happening, as soon as we find the crop circle, there are columns of steam coming out of them.

With such energetic interactions, it is very conceivable that these temples are

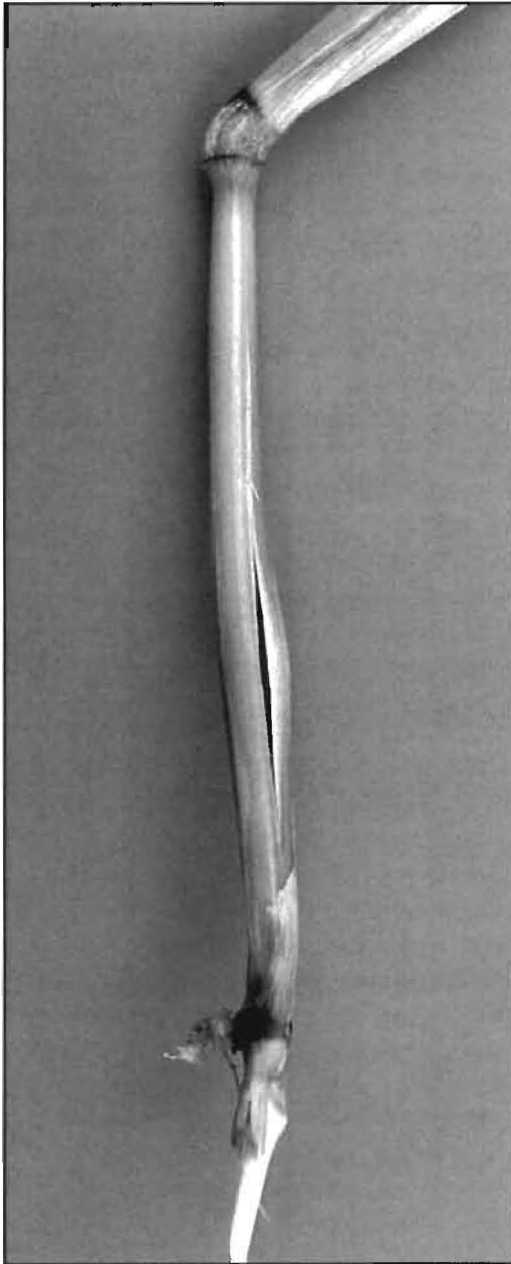

Figure 23. Heat scarred wheat stem

influencing biological systems. They may be influencing the Earth's energy grid, and the people who come into contact with them. We know there is certainly an input of energy taking place because many of the eyewitnesses that have seen crop circles appearing talk about beams of light in front of them, creating the circles right in front of their eyes.

So to try and sum this up: All the temples, regardless of what they look like, they're all built on strategic points of the Earth's electromagnetic grid. They are all founded on the principles of sound and sacred geometry, and all such resonances have a potential to alter molecular structures, because all the atoms that make up the physical world, including the human body, are themselves in a state of vibration.

You remember about an hour ago I made a connection with water, how it's so important to all sacred sites. Well I'm going to leave you all with this to think about, because the final connection I want you to consider on how sacred space can alter human consciousness and create very miraculous spaces on earth, is that the crop circles, the churches and all sacred spaces also connect through water.

When you exert spin motion of energy over water, you generate an electromagnetic field, and this has been measured in crop circles. Now, we know that water has memory. We know this from eight thousand years ago, when the Egyptian creation god Djehuty, or Thoth as we call him in Greece, said that "Yes, when you

dilute a few drops of a solution a million times, and you shake it vigorously you retain the memory of that solution.” Jacques Benveniste in the recent era, also proved that when you take four drops, diluting it a million times, shaking vigorously, putting it under a microscope and “hey, presto!” the memory of that solution is still there. We of course call it homeopathy. We began to bury samples of water inside the crop circles, found and dug up the bottles by dowsing for them. Lucy Pringle sent some of these samples to Jacques Benveniste, and Benveniste found that the samples that came from the crop circles were coded up to 135% above normal. The implication here is very, very serious because 80% of the worlds reported crop circles appear in Southern Britain, which happens to sit on the World’s deepest chalk aquifer.

The other greatest concentration of crop circles appears in the Canadian prairie, which happens to sit on a limestone aquifer. Chalk is a chemical twin of limestone. Consider how an aquifer works. All of that coded water is leeching through the aquifer, and is leeching into the streams, the rivers, and the oceans around the world. And, by the homeopathic method, becomes greater in its capacity. So consider this, if the crop circles are actually encoding the oceans, the oceans occupy two-thirds of the body of the planet. Then also consider what these miraculous new temples are doing to the human body. Because we too, are two-thirds water. Thank you very, very much for having me here.

• • •

CORRESPONDENCE: Freddy Silva • lovely272@earthlink.net • www.cropcirclesecrets.org
www.invisibletemple.com

REFERENCES & NOTES

1. This paper is based on Freddy Silva’s Keynote Address presented at the Seventeenth Annual ISSSEEM Conference, *The Science of the Miraculous* (June 21-27, 2007). The address is based on his work *Secrets In The Fields: The Science and Mysticism of Crop Circles*, Hampton Roads, VA, 2002

∞ ∞ ∞